



(RESEARCH ARTICLE)



A low-cost prosthetic arm with real-time haptic feedback and gesture control for enhanced user autonomy

Nikhil Sakthirajan *

Dublin High School, Dublin, California, USA.

World Journal of Advanced Research and Reviews, 2024, 24(01), 1365–1372

Publication history: Received on 05 September 2024; revised on 13 October 2024; accepted on 15 October 2024

Article DOI: <https://doi.org/10.30574/wjarr.2024.24.1.3050>

Abstract

In daily life, manipulating and feeling objects is essential for autonomy and engagement in various activities. However, individuals relying on prosthetic limbs often encounter barriers such as high costs, ineffective feedback, and limited design adaptability. Unlike conventional prosthetic limbs, which frequently struggle to integrate seamlessly and provide intuitive control, the robotic arm outlined in this study represents a leap in functionality and user experience. At the core of its design lies a specialized glove outfitted with a calibrated array of flex-sensing resistors capable of precisely detecting and interpreting the wearer's movements. These sensors input to the robotic arm, translating the user's gestures into motions that follow human hands. The fingertips are equipped with force-sensing resistors to discern the magnitude of force applied during gripping actions. This real-time sensory feedback is conveyed to the user through a haptic system integrated into the glove. By modulating the intensity and pattern of vibrations, users can gauge their grip strength and manipulate their grasp of the object accordingly. Comprehensive experiments were conducted across various scenarios to assess its performance, agility, strength, and sensory accuracy. Through refinement, the author aims to optimize functionality and reliability, enhancing practicality for users. This project has broader implications for the prosthetics community. By utilizing the scalability and cost-effectiveness of this model, the author envisions tailored solutions that empower individuals with limb differences to live more independently.

Keywords: Prosthetics; Wearable Robotics; Human – Machine Interactions; Haptic Feedback; Control Systems

1. Introduction

Limb loss is a prevalent issue today, especially with the rise of several vascular diseases. It is estimated that by 2050, there will be 4 million amputees in just the USA (Ziegler 2008). Object manipulation is essential in accomplishing activities of daily living, and loss of this ability can severely hinder many people. Experiencing tactile feedback, or being able to feel objects, is critical in accomplishing daily activities because the micro-receptors in the skin provide important tactile cues for grasping and manipulation. However, amputees who utilize a prosthesis cannot sense those tactile cues. To remedy this, recent studies have implemented a haptic feedback system using piezo vibration sensors, which generate electrical currents when stress is applied to a metal plate (Premarathna 2018). It was found that such feedback solutions deliver tactile feedback with a delay. Despite this, it was also found that the manipulation based on real-time feedback was difficult to achieve using piezo-vibration sensors because the longer delay provided inaccurate results (Premarathna 2018). In other recent studies, electromyography connected prosthetic arms via nerves (Corbett 2011, Fougner 2016). Those implementations were considered extremely useful for many amputees because the improved sense of touch and awareness of the stiffness of the objects helped users better control the prosthesis (Segas 2023). However, electromyography (EMG) sensors are not cost-effective and require complex control algorithms. EMG sensors may produce incorrect data from the activity of other muscles and 'noise,' or in other words, interference from the signals from other electrical devices. While there are two widely used forms of EMG, surface EMG and intramuscular

* Corresponding author: Nikhil Sakthirajan

EMG, intramuscular EMG often produces the best results but requires sensors under the skin, making it a complex endeavor (Turker, 1993).

In this work, I present a leader-follower control system wherein a follower prosthetic will mimic the movements of the leader glove, and the prosthesis will provide haptic and force feedback to the glove. This control system has been used to control robotic limbs and is extensively used in the medical field and areas with hazardous waste that poses a risk to humans. One study has used the leader-follower system to assist in medical surgery (Hwang, 2019), highlighting the range of applications for this control system. More recently, this control system has been implemented in virtual reality and used for virtual-physical interactions (Liu, 2023). This control system has also been used to create a wirelessly controlled prosthetic (Karam, 2018), where the leader-follower system allowed for individual control of the fingers of the prosthesis. The 'leader' glove will employ Adafruit 1070 flexible sensors made with polymer-based materials in this study. The sensors have a response time of less than 10ms and low power consumption - drawing around 0.5W. The prosthesis will be fitted with force-sensing resistors (FSR) from Adafruit. FSRs consist of two membranes that have a semiconductive material between them. The sensor's resistance decreases as force is applied on one side of the FSR. While FSRs are low-cost and straightforward, they provide a range of values for the force applied rather than an exact number. This makes the sensors inaccurate for applications when detecting the precise force, but they are helpful for touch-sensitive applications. The 'leader' glove also contains Adafruit 1201 vibration motors. Vibration motors are small, circular (10mm diameter) motors that vibrate proportionate to the voltage supplied— a higher voltage results in increased vibration intensity. The vibrating capabilities from the motors can provide tactile feedback based on the object being grasped.

In this work, the fabrication of the hand and forearm with a 3D printer using Polylactic Acid (PLA) filament in an anthropomorphic design is completed. The logic for the prosthetic is provided by an Arduino MEGA (Elegoo Board). I chose Arduino as it is low-cost and open-source, offering accessibility and flexibility for potential future users. The Arduino MEGA was chosen over the Uno because the MEGA had 11 analog input ports needed to hook up the 10 FSRs and Flex Sensors. The hand is actuated using a Tendon-Driven mechanism where the fishing line, which acts as tendons in a finger, is pushed and pulled by a servo motor. The circuit will detect the input from the human hand using the flex sensors mounted on the glove. The Arduino will translate that motion signal into angles for the servo motor to actuate, thus bending a finger.

In this work, I develop a prosthetic hand with a leader-follower control system that can grasp various objects and provide haptic feedback. The work showcases the usage of FSRS in prosthetics and highlights the value of grip control and haptic feedback in a prosthesis. Using off-the-shelf components, I present a novel implementation of a prosthetic hand that can complete three tests where the prosthetic must grip several objects utilizing the haptic feedback and grip manipulation function.

2. Prosthetic Design

The prosthesis consists of a forearm, palm, and five fingers. All parts are manufactured using Matte White PLA on a Bambu P1P FDM 3D Printer. 3D printing is commonly used for fabricating such devices due to its ease and inexpensive nature (Gupta 2022, Fulzele 2020, Hebert 2016). The arm designs are taken and modified from InMoov's Open-Source Robot Design. Previous studies have used this design (Karam 2018), proving its efficacy in prosthetics research.

Each finger is composed of three joints with flanges at each joint. Each joint is circular, allowing the tendons to run through the fingers. For this work, each joint is connected using a floral wire, which acts as an axle. Figure 1 gives a visual of a finger and how the joints connect.

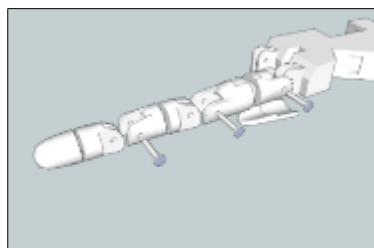

Figure 1 CAD Design for finger three demonstrating how the finger is assembled

The thumb utilizes two joints and is connected to a larger palm hinge, allowing it greater freedom, like the thumb joint on the human hand. The fourth and fifth fingers also feature a larger hinge connected to the palm. Figure 2 shows the thumb, its joints, and the larger joint connecting to the palm.

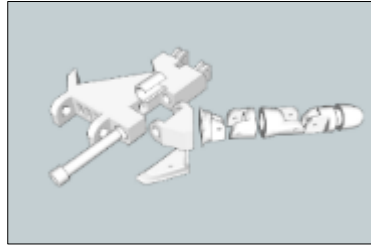

Figure 2 CAD design for the palm and thumb showing the thumb is connected to the palm.

The palm of the prosthesis is the center to which all the fingers and joints connect. The inside of the palm has various holes and grooves that allow the tendon/string to pass through and run up through the fingers, which are connected to circular hinges placed at the edge of the palm. These pathways are segmented into more minor pathways routing to the individual fingers, ensuring that the tendons move smoothly. Figure 3 provides a focused view of the palm and shows how it is assembled.

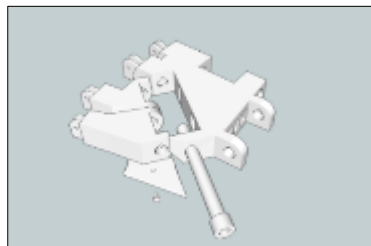

Figure 3 CAD design for the palm shows the hinge for the 4th and 5th fingers, showing how the palm is put together

The forearm is separated into two main sections, one used to route the cables and the other used for mounting the servos. The first half has segmented pathways so that the tendons can move smoothly. In addition, a mounting location for a 6th servo allows for complete wrist rotation, providing additional rotary movement for the prosthetic arm. For the purposes of this paper, this movement is not utilized; However, this will be beneficial for providing more physiologic movement in future prototypes. The servo motors are also arranged to match the tendons' routing. Figure 4 shows the lower half of the forearm and where the servos are mounted.

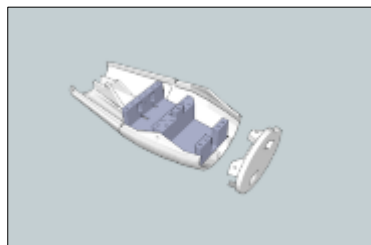

Figure 4 CAD design for the forearm showing the servo bed where the motors are mounted

The overall hand is powered by a Tendon-Driven Mechanism (TDM), which is commonly used in other prosthesis implementations (Carroza, 2005). In a TDM, the braided fishing wire is steered by pulleys, pulling the fingers up and down. The pulleys are mounted to the servo and custom-made to fit the steering rod packaged with the servo. Figure 5 shows a visual for the TDM mechanism along with an image of the whole assembled arm.

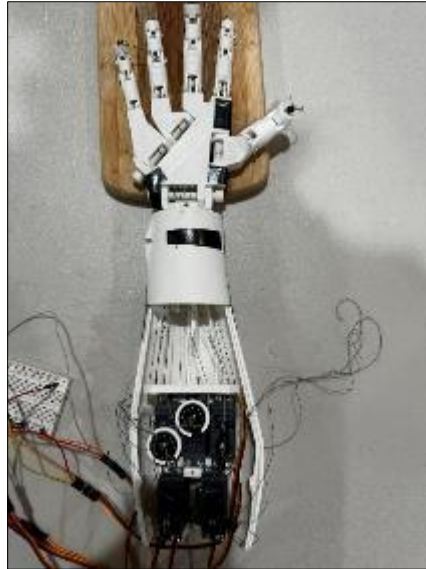

Figure 5 Assembled right arm along with the TDM Mechanism in the forearm

3. Leader – Follower System

The prosthesis processes transmitting and receiving signals using an Arduino MEGA board.

The Flex Sensors can sense the motion of the fingers as they bend and send this signal to Arduino MEGA. When bent, the flex sensor has an increased resistance, relaying this change in resistance to the Arduino. The flex sensor's resistance is proportional to how much the sensor is bent. These flex sensors are fastened onto a glove that fits the human hand, and the flex sensors bend in tandem with the movement of the human fingers, which can be seen in Figure 6.



Figure 6 Glove with the flex sensors attached

The force exerted on an object is measured by receiving the signal from the force-sensing resistors. Force-sensing resistors (FSRs), with a diameter of 0.72 inches, are mounted on the prosthesis and are used to measure force. As pressure is put on the sensor, the resistance decreases proportionately. The FSRs on the prosthetic send feedback to the MEGA, adjusting the intensity for the vibration motors and providing tactile feedback. Figure 7 shows the prosthetic with the FSRs fastened.



Figure 7 Prosthetic with an FSR mounted onto the upper palm

The leader circuit contains the flex sensors on the glove, which send the signals from the finger movement to the Arduino MEGA. After receiving the signals, the MEGA converts that motion signal into a usable input for the follower algorithm. The leader circuit also contains the FSRs, which send the signals from the pressure applied on an object to the Arduino MEGA. Like the flex sensor, the Arduino MEGA converts the force reading into a usable input for the follower algorithm. Since the entire circuit utilizes only one card, the inputs are sent through wires. Figure 8 shows the circuit diagram for the leader-follower system for only one finger.

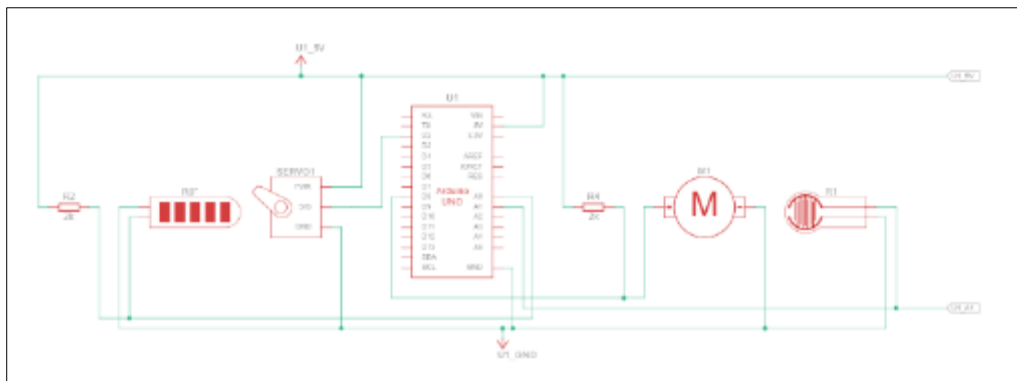

Figure 8 Tinkercad render of the circuit diagram for the leader-follower circuit

The same Arduino MEGA controller also processes the receiving/follower circuit. The board takes the signal from the flex sensor and uses it as the control signal for the DC servos. The servos move from an angle of 0° to 180° , which is equivalent to the bending signal received from the flex sensors in the master circuit. This will allow the prosthesis to grasp an object. The board then takes the signal from the FSRs on the glove and prosthesis, and based on the force reading, the servo is repositioned, and the prosthesis adjusts its grip on the object. This allows the prosthesis user to experience an artificial sense of grip strength.

4. Control Algorithm

A C++ algorithm is part of the leader-follower system and is put in place for processing and translating the data received in the leader-follower system. As mentioned before, the flex sensor's resistance changes based on the bending of the human finger. Per the manufacturer's website, this resistance ranges from $25k\Omega$ to $100k\Omega$. The change in resistance is read by the analog input pin of the Arduino, classified to a specific variable, and then converted into voltage levels that make the servo motors rotate from 0° to 180° . This conversion is done using the mapping function of the Arduino IDE. To control the haptic feedback on the prosthesis, the mapping functionality is again used to map the resistance on the FSR to a value on the haptics. The haptic motors are connected to the digital pins on the Arduino, and FSR input is translated the same way the Flex Sensor Conversion works.

5. Testing

Three physical tests for the prosthesis were conducted. The initial assessment constitutes a fundamental examination of the grip manipulation system without using haptic feedback. In this trial, the prosthetic is tasked with securely grasping objects for 3 minutes without slipping. The standard of 3 minutes was chosen because that is the average amount of time a person may hold a water bottle throughout a 24-hour period. The timer was stopped when the object slipped out of the prosthetic. Five commonly used objects of varying sizes and shapes were chosen to evaluate their grasping abilities. We saw that for this test, the prosthetic had difficulty holding smaller objects but could hold larger objects for around 150 seconds (Table I).

Table 1 Data for the First Gripping Test

Object	Time Held Without Slippage (Seconds)
Camelback Water Bottle	152
Pliers	120
Screw Driver	80
Fork	64
Tennis Ball	154

Subsequently, a rudimentary evaluation of the haptic feedback mechanism proceeds with the first assessment. Here, the prosthetic engages with various objects, with the primary objective being to determine the user's ability to discern object presence through haptic feedback sensation. A secondary objective of having the user correctly discern which type of object is present is also sought in this test. The results of this test can be found in Table II.

Table 2 Data for Haptic Feedback Test

Test Object	Camelback Water Bottle	Screw Driver	Pliers	Fork	Ball
Guessed Object	Yes	Yes	Yes	Yes	Yes
Identified Object	Yes	No	No	No	Yes
%Yes	100%	50%	50%	50%	100%
%No	0%	50%	50%	50%	0%

The culmination of the assessment protocol involves a tertiary examination aimed at elucidating the impact of haptic feedback integration on grip manipulation efficacy. This is achieved by replicating the initial grip manipulation trial, albeit extended to 4 minutes because the prosthetic could hold objects for a more extended time. This assessment focuses on discerning any enhancement in grasping duration due to haptic feedback implementation. Table III collects the data for this experiment.

Table 3 Results for Test 3

Test Object	Time Held Without Slippage (Seconds)
Camelback Water Bottle	240
Pliers	194
Screw Driver	156
Fork	95
Tennis Ball	203

6. Discussion

The testing and subsequent results highlight several aspects of this prosthetic and its control system. First, implementing the haptic feedback system in conjunction with the grip manipulation system has led to a significant increase in the time the objects were held. On average, this increase amounted to 63.6 seconds, demonstrating that it was easier to hold and use objects by adding the haptic feedback and grip manipulation systems. Furthermore, the haptic feedback allowed the user to recognize different aspects of different objects, which would make it easier for them to handle different objects, evident in how the user was able to manipulate the grip of the prosthetic according to the intensity of the haptic feedback. One issue immediately noticeable with the prosthetic is its inability to hold smaller objects. The prosthetic had difficulties utilizing objects like the fork, mainly because it could not grip it all the way, and the fork would constantly slip. This indicates that the prosthetic has difficulty grasping smaller objects. Despite this setback, the implementation of the grip manipulation and haptic feedback systems proved successful in the testing.

7. Conclusion and Future Work

A prosthetic hand has been designed and tested to mimic the motion of a human hand and hold various commonly used objects. This device utilizes a leader-follower system, where the leader, control glove, and follower, or the prosthetic arm, have been designed to communicate with each other. This control system allows for individual manipulation of the fingers on the prosthetic arm, allowing the user to manipulate the grip on an object precisely. A haptic feedback mechanism is integrated into the prosthesis, utilizing force-sensing resistors to provide accurate tactile feedback. These systems were tested in a series of trials that qualified whether the prosthetic could pick up and utilize objects of daily use. The results of this trial establish that this prosthesis is effective in completing tasks of daily living, such as picking up a water bottle and cutlery, and successfully picking up and grasping all of the objects being tested. The haptic feedback implementation, however, could be improved as the vibration and intensity of the motors would be too much compared to the force detected by the prosthesis. In future work, integrating wireless connectivity for the master glove, which would utilize an Arduino-compatible Bluetooth card, would be among the most significant changes. This would allow the user to control the prosthesis using the control glove without being tethered to wires and cables. Additionally, implementing spring tensioning for the tendon-driven mechanism would prevent the string from loosening after some time and reduce the prosthesis's maintenance. Finally, the portability of the prosthesis will be improved by adjusting the density of the print and the motor placement in the prosthesis to adjust the weight and make the prosthetic arm functionally portable.

Compliance with ethical standards

Disclosure of conflict of interest

No conflict of interest to be disclosed.

References

- [1] Karam, Z. A., Al-Kadhimi, A. M., and Saeed, E. A. (2018). "Design and implementation of a wireless robotic human hand motion-controlled using Arduino," in 2018 International Conference on Advanced Science and Engineering (Duhok: ICOASE).
- [2] Corbett EA, Perreault EJ, Kuiken TA. Comparison of electromyography and force as interfaces for prosthetic control. *J Rehabil Res Dev.* 2011;48(6):629-41. doi: 10.1682/jrrd.2010.03.0028. PMID: 21938651; PMCID: PMC4316207.
- [3] C. P. Premarathna, I. Ruhunage, D. S. Chathuranga and T. D. Lalitharatne, "Haptic Feedback System for an Artificial Prosthetic Hand for Object Grasping and Slip Detection: A Preliminary Study," 2018 IEEE International Conference on Robotics and Biomimetics (ROBIO), Kuala Lumpur, Malaysia, 2018, pp. 2304-2309, doi: 10.1109/ROBIO.2018.8665044.
- [4] Nhon P. N. Q., et al. "Intelligent Control of Rehabilitation Robot: Auto Tuning PID Controller with Interval Type 2 Fuzzy for DC Servomotor." *Procedia Computer Science* 42 (2014): 183-190.
- [5] Hande1 J., et al. "Design for Robotic Hand Using Flex-sensor." *International Journal of Advanced Research in Electronics and Communication Engineering* 4.12 (2015): 2846-2850.

- [6] M. C. Carrozza et al., "A Cosmetic Prosthetic Hand with Tendon Driven Under-Actuated Mechanism and Compliant Joints: Ongoing Research and Preliminary Results," Proceedings of the 2005 IEEE International Conference on Robotics and Automation, Barcelona, Spain, 2005, pp. 2661-2666, doi: 10.1109/ROBOT.2005.1570515.
- [7] M. C. Carozza et al., "On the development of a novel adaptive prosthetic hand with compliant joints: experimental platform and EMG control," 2005 IEEE/RSJ International Conference on Intelligent Robots and Systems, Edmonton, AB, Canada, 2005, pp. 1271-1276, doi: 10.1109/IROS.2005.1545585.
- [8] A. Fulzele, H. Kocha, A. Jain, D. Sawant and A. Raut, "3D Printed Prosthetic Arm," 2020 IEEE 15th International Conference on Industrial and Information Systems (ICIIS), RUPNAGAR, India, 2020, pp. 109-114, doi: 10.1109/ICIIS51140.2020.9342659.
- [9] Ramlee MH, Ammarullah MI, Mohd Sukri NS, Faidzul Hassan NS, Baharuddin MH, Abdul Kadir MR. Investigation on three-dimensional printed prosthetics leg sockets coated with different reinforcement materials: analysis on mechanical strength and microstructural. *Sci Rep.* 2024 Mar 21;14(1):6842. doi: 10.1038/s41598-024-57454-8. PMID: 38514731; PMCID: PMC10958049.
- [10] Hand Design, <http://inmoov.fr/hand-and-forarm>, May,2018
- [11] Türker KS. Electromyography: some methodological problems and issues. *Phys Ther.* 1993 Oct;73(10):698-710. doi: 10.1093/ptj/73.10.698. PMID: 8378425.
- [12] Hasan S. (2016). Biomechatronic Design Optimization of Anthropomorphic Artificial Han for Prosthetic. (Unpublished master's thesis). AL-Nhrain University, Bagdad, Iraq.
- [13] Fougner, A., Stavdahl, Ø., & Kyberd, P. J. (2016). System training and assessment in simultaneous proportional myoelectric prosthesis control. *Journal of NeuroEngineering and Rehabilitation*, 13(1), 1-12.
- [14] Ziegler-Graham, K., MacKenzie, E. J., Ephraim, P. L., Travison, T. G., & Brookmeyer, R. (2008). Estimating the prevalence of limb loss in the United States: 2005 to 2050. *Archives of Physical Medicine and Rehabilitation*, 89(3), 422-429.
- [15] Hebert, J. S., Olson, J. L., Morhart, M. J., & Dawson, M. R. (2016). Marzena. Rapid prosthetic socket fabrication using digital technology. *Prosthetics and Orthotics International*, 40(2), 204-211.
- [16] Segas E, Mick S, Leconte V, Dubois O, Klotz R, Cattaert D, de Ruyg A. Intuitive movement-based prosthesis control enables arm amputees to reach naturally in virtual reality. *Elife.* 2023 Oct 17;12:RP87317 doi: 10.7554/eLife.87317.PMID: 37847150; PMCID: PMC10581689.