



(REVIEW ARTICLE)



SPBCSEV: Solar Power Based Charging Station for Electric Vehicles

Sunilkumar M. Hattaraki, Achyut S Yaragal, Rani U.Rotti * and Pavitra A.Hiremath

Department of Electronics and Communication Engineering B.L.D.E. A's V. P. Dr. P. G. Halakatti College of Engineering and Technology, Vijayapura, Karnataka, India.

World Journal of Advanced Research and Reviews, 2023, 18(02), 430–434

Publication history: Received on 29 March 2023; revised on 07 May 2023; accepted on 09 May 2023

Article DOI: <https://doi.org/10.30574/wjarr.2023.18.2.0825>

Abstract

Electric vehicles, which are in high demand these days, emit no tailpipe emissions, significantly reducing smog and greenhouse gas emissions. Electric vehicles use electricity to recharge their batteries rather than fossil fuels such as petrol and diesel. Electric vehicles are more efficient, and when combined with the cost of electricity, charging an electric vehicle is less expensive than filling up with petrol or diesel. With the growing demand for electric vehicles, there is a greater need for dependable and long-term charging infrastructure or systems. The purpose of this paper is to provide a sustainable and convenient charging solution for electric vehicles by utilizing renewable energy sources such as solar power. Furthermore, an electric vehicle charging station is created using an Arduino microcontroller, wireless charging coil modules, a solar panel, and an ESP8266 Wi-Fi module.

Keywords: Arduino; Electric Vehicles; Charging Stations; Solar Panel

1. Introduction

As the world moves towards more sustainable development, electric vehicles (EVs) are becoming more popular as an environmentally friendly alternative to traditional gasoline-powered vehicles. However, one of the major barriers to widespread EV adoption is a lack of adequate charging infrastructure. This is where a smart solar plus IoT wireless charging system for electric vehicles comes in. This system is an innovative solution that uses renewable energy sources like solar power to wirelessly charge electric vehicles, making them more accessible and convenient for consumers.

With the growing popularity of electric vehicles, there is an increased demand for a dependable and sustainable charging infrastructure. According to Bloomberg New Energy Finance, the number of electric vehicles on the road is expected to rise from 2 million in 2016 to 30 million by 2025. This emphasizes the importance of a strong charging infrastructure to support this growth. The smart electric vehicle solar plus IoT wireless charging system is a novel solution that can assist in meeting this need. Using renewable energy sources such as solar power, this system aims to provide a sustainable and convenient charging solution for EVs.

2. Related Work

A. Singh et al. [1] presented findings from the design of a solar-powered EV charging station for the Indian market. The analysis has been deliberated on the basis of the number of cars charged annually, the monthly variation in energy generation, the investment cost, and It can annually charge 414 vehicles with 30 kWh battery capacity.

This would contribute to a 7950 kg reduction in annual CO₂ emissions. Maximum energy production occurs near the equator in March or January, and maximum energy production occurs near the Tropic of Cancer in May-June. When monocrystalline modules are used, the overall system generates more energy and saves money.

* Corresponding author: Rani U.Rotti

Ataur Rahman et al [2] developed created an on-board charging system with three different charging modes: slow charging for residential use, medium charging for office parking lots, and fast charging for charging stations on the road. With a maximum charging current of 50 A and an automatically activated quick evaporative thermal management system, the quick charging mode charges the battery in 1.5 to 2.0 hours. The quick charging system's performance has shown that the battery can be charged up to 85% of its rated capacity using constant current mode rather than constant voltage, which has reduced battery charging time by 16%. However, due to the fast redox reaction of the battery's electrochemistry, it may reduce battery life by about 5%.

Brenna et al. [3] provided an overview of existing and proposed EV charging technologies in terms of converter topologies, power levels, power flow directions, and charging control strategies. An overview of the main charging methods is also provided, with the goal of highlighting an effective and fast charging technique for lithium ion batteries in terms of extending cell cycle life while maintaining high charging efficiency. After presenting the most important aspects of charging technologies and strategies, the final section of this paper estimates the optimal size of charging systems using a genetic algorithm and values possible future trends in this field based on a sensitive analysis.

Syed Asad Abbas Rizvi et al [4] discussed many key issues such as forecasting, power quality, and the effect of charging and discharging EVs on the grid, as well as alluded to ambiguous issues to present guidelines to many research areas. According to research studies related to the development, the distribution system is the most impacted segment of the power system as a result of EV integration. Transmission line congestion can have an impact on both generation and transmission levels in extreme cases. The primary research topics in power quality are harmonic distortion and voltage imbalance. Some of the fringe issues are rising power losses and node voltage drops. Many researchers agreed that significant effects on power quality would be noticeable only at higher levels of EV integration penetration. The charging of EVs has the greatest impact on the power grid in terms of load capacity, power quality, grid economy, and environmental changes. EVs have a positive impact on the environment because they reduce CO₂ emissions.

Chandra Mouli et al [5] investigated a solar-powered e-bike charging station that offers AC, DC, and wireless charging of e-bikes. The charging station includes integrated battery storage, allowing for grid-connected and off-grid operation. The e-bike can be charged wirelessly by inductive power transfer via the bike kickstand (receiver) and a specially designed tile (transmitter) at the charging station, providing maximum convenience to the user.

Gheorghe Badea et al [6] investigated the possibility of using solar autochthonous renewable resources to charge electric vehicle batteries with clean energy. A charging station for electric vehicles with photovoltaic panels and batteries as main components was designed, dimensioned, and operationally simulated. We simulated the operation of the photovoltaic system after optimising its configuration with improved Hybrid Optimisation by Genetic Algorithms (iHOGA) software version 2.4. The solar energy system must be designed in such a way that the charging station always has enough electricity to supply several electric vehicles 24 hours a day. The main findings concerned the system's energy, environmental, and economic performance after one year of operation.

T. S. Geetha et al. [7] proposed a novel capacity expansion framework for electric vehicle charging stations (EVCSs) based on short-term functional decisions and long-term planning in the presence of stochastic power demand. Energy is supplied to the microgrid by solar, wind, energy storage systems, and microgas turbines. An EVCS is a vehicle-to-grid (V-G) system that can send energy to a microgrid. Capacity expansion planning in a microgrid can increase the capacity of solar panels, storage systems, and wind turbines. The short-term and long-term expansion problems were solved by optimising resource hourly operation and using a five-year planning horizon, respectively. The effect of the availability of various resources, such as wind, solar, and V-G power, on system performance has been investigated. Finally, the proposed method was compared to three other algorithms, and the results show that it is superior.

3. Proposed Methodology

The below Fig.1. depicts that Block diagram of Proposed System .The solar panel generates electricity that is used to charge the EV's battery. The IR sensor detects the EV's presence and sends a signal to the Arduino microcontroller when it approaches the energy station. The microcontroller activates the relay module, which turns on the power supply to the energy station's wireless charging coil module. This produces a magnetic field, which induces a current in the EV's wireless charging coil module. The charge is received by the EV's coil module, which then charges the 3.7v rechargeable battery. In addition, the system monitors the charging status of the EV and displays the voltage and battery level on the energy station's LCD display. Furthermore, the ESP8266 Wi-Fi module sends the car's status to a Thingspeak account in the form of 0 and 1, allowing users to remotely monitor the charging process. If the EV's battery is not fully charged, the system can charge it with solar energy. The solar panel converts sunlight into electricity, which is then used to charge the EV's battery.

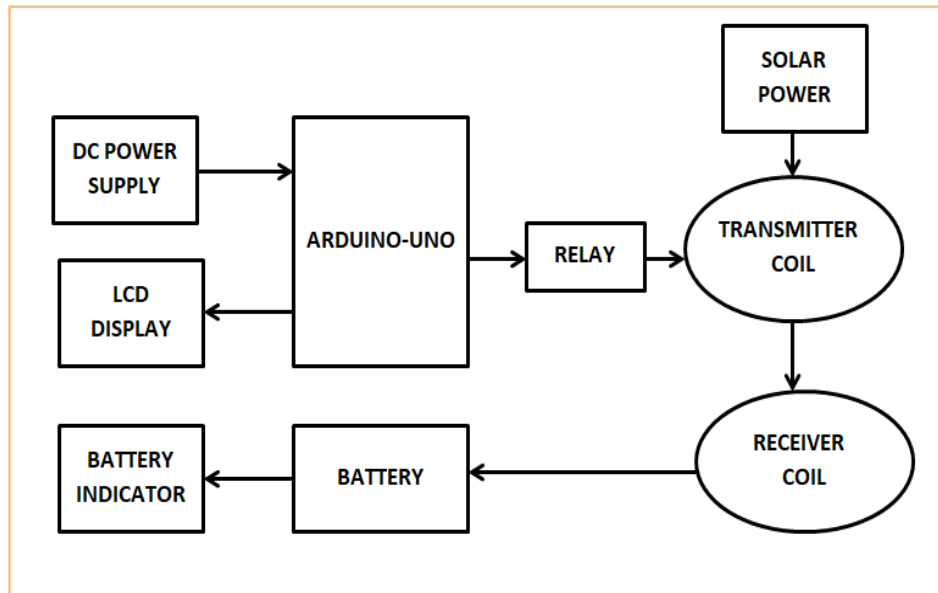

Figure 1 Block diagram of Proposed System

The following steps are taken to develop a SPBCSEV-Solar Power Based Charging Station For Electric Vehicles

- Requirement Analysis: We identified the requirements for a long-term and efficient EV charging system, as well as the hardware and software components required.
- Hardware and Software Design: We created the system's hardware and software, which included the Arduino microcontroller, wireless charging coil modules, solar panel, and ESP8266 Wi-Fi module.
- System implementation: We built the hardware components and wrote the software code.
- Testing: To ensure the system's reliability and efficiency, we tested its functionality and performance under a variety of conditions and scenarios.
- Deployment: We put the system into production and tracked its performance and user feedback.

3.1. Components used for Proposed System

- Solar panel: A solar panel is a group of panels that capture sunlight and convert it into electrical energy. Typically, the panels are installed on a roof or a separate structure near the charging station.
- Battery: This component stores excess solar panel power for use during periods of low sunlight or high demand.
- DC Power Supply: This supplies power to the charging station when the solar panels are unable to produce enough energy.
- Arduino microcontroller: This microcontroller serves as the charging station's brain, controlling the flow of power to the vehicle.
- LCD Display: This shows the charging station's status, including the battery level, charging rate, and other information.
- Battery indicator: This shows the battery's current charge level.
- IR Sensor Array: This detects the presence of an electric vehicle and initiates charging.
- Relay: This regulates the power flow from the battery to the transmitter coil.
- Transmitter coil: This wirelessly transfers power to the electric vehicle's receiver coil.
- Receiver coil: This coil wirelessly receives power from the transmitter coil and delivers it to the battery of an electric vehicle.
- ESP8266: This Wi-Fi module connects the charging station to the internet and allows it to communicate with other devices.
- Thing Speak IoT: This platform collects data from charging stations and provides analytics and visualization tools to help with charging process monitoring.

Overall, this system enables electric vehicles to be charged using solar energy and provides advanced monitoring and control capabilities via the IoT platform. Wireless charging eliminates the need for cables, providing more flexible charging options. The use of an Arduino microcontroller provides a platform that can be customized and expanded in the future.

4. Results and Discussion

The below figure 2 depicts the working module of the proposed system, which is the interconnection of a solar panel, an Arduino-Uno, a battery, a DC power supply, an IR sensor array, a battery indicator, a transmitter coil, a receiver coil, and an ESP8266.

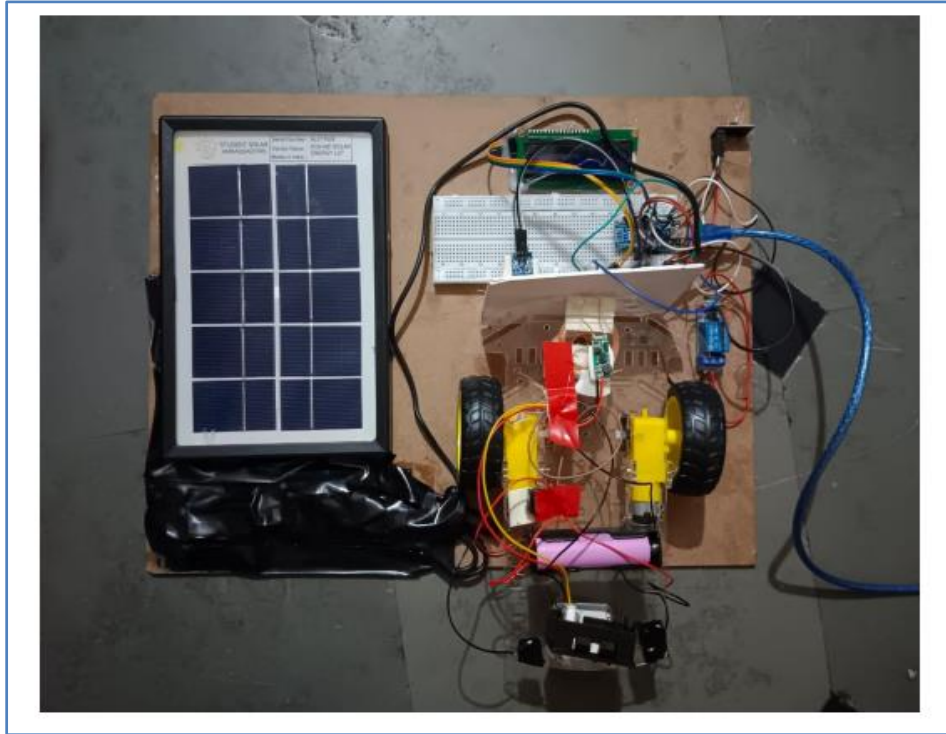

Figure 2 Working Module of Proposed System

5. Conclusion

The use of solar panels to power electric vehicle charging stations has the potential to be an effective and environmentally friendly solution, but its feasibility and effectiveness will be determined by a variety of factors unique to each location and system. In the coming years, ongoing research and development will most likely improve the efficiency and viability of solar-powered electric vehicle charging stations.

Compliance with ethical standards

Acknowledgements

We would like to express my deepest gratitude to our guide Prof. Sunilkumar M.Hattaraki and Prof.Achyut S.Yaragal, for their consistent motivation and aid at some point of the direction of the work.

Disclosure of Conflict of interest

To the best of our knowledge, the named authors have no conflict of interest in any form.

References

- [1] A. Singh, et al, "Design and Analysis of a Solar Powered Electric Vehicle Charging Station for Indian Cities," World Electr. Veh. J., vol. 12, no. 3, pp. 2, 2021.
- [2] Development of rapid charging system for EV battery, International Journal of Recent Technology and Engineering (IJRTE), ISSN: 2277-3878, Volume-7, Issue-6S, March 2019.

- [3] Brenna, M., Foiadelli, F., Leone, C. et al. Electric Vehicles Charging Technology Review and Optimal Size Estimation. *J. Electr. Eng. Technol.* 15, 2539–2552 (2020). <https://doi.org/10.1007/s42835-020-00547-x>.
- [4] Rizvi SAA, Xin A, Masood A, Iqbal S, Ullah Jan M, Rehman H (2018) Electric vehicles and their impacts on integration into power grid: a review. In: Presented at the 2nd IEEE Conference on Energy Internet and Energy System Integration (EI2), Beijing, China, Oct. 20–22, 2018.
- [5] Chandra Mouli, G.R.; Van Duijsen, P.; Grazian, F.; Jamodkar, A.; Bauer, P.; Isabella, O. Sustainable E-Bike Charging Station That Enables AC, DC and Wireless Charging from Solar Energy. *Energies* 2020, 13, 3549.
- [6] Badea, G.; Felseghi, R.-A.; Varlam, M.; Filote, C.; Culcer, M.; Iliescu, M.; Răboacă, M. Design and Simulation of Romanian Solar Energy Charging Station for Electric Vehicles. *Energies* 2018, 12, 74.
- [7] T. S. Geetha, ,V. Amudha and C. Chellaswamy, “A Novel Dynamic Capacity Expansion Framework Includes Renewable Energy Sources for an Electric Vehicle Charging Station”,*International Transactions on Electrical Energy Systems*, 2022.